

Technical specification

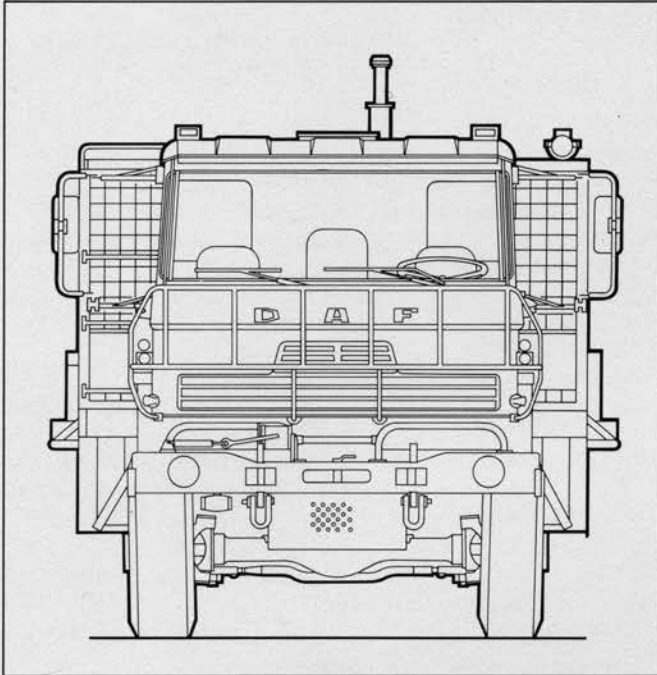

**DAF YGZ 2300 DHS 6 x 6 bridging vehicle
with 6,5 tonnes cross country payload**

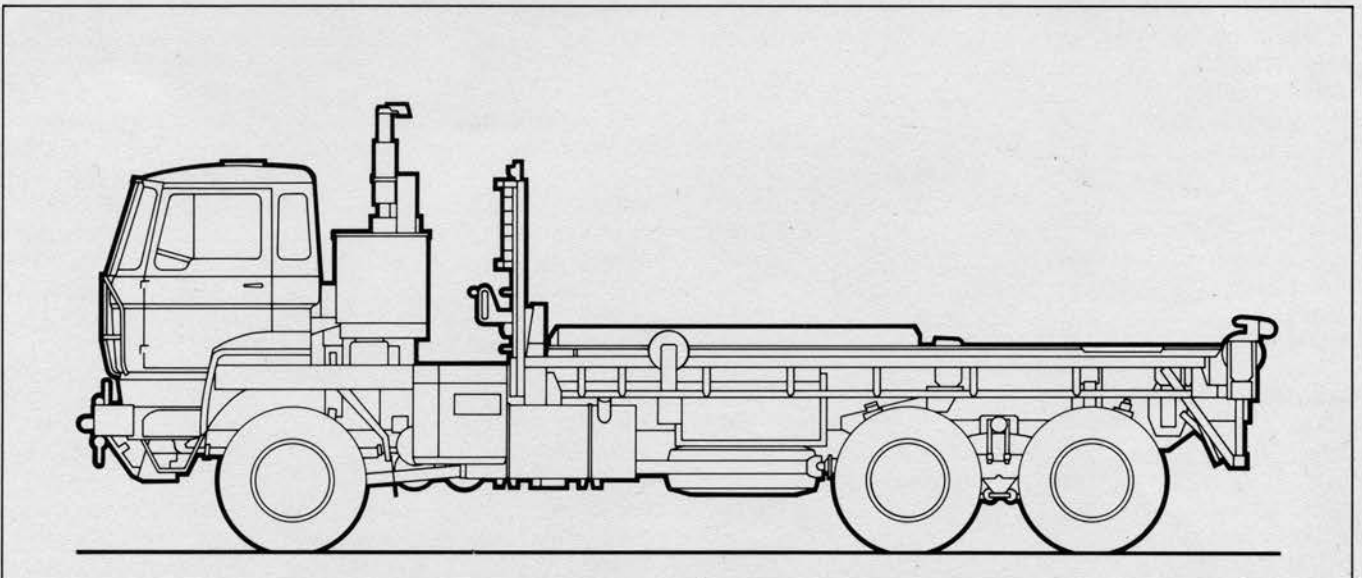

DAF International Military
Co-ordination
Hugo van der Goeslaan 1
5643 TW Eindhoven
Tel.: 040-142872
Telefax 040-115456
Telex 51980 DAF BP NL

The specifications contained herein were in effect at the time this pamphlet was approved for release. They are subject to modification without prior notice.

DAF YGZ 2300 DHS 6 x 6 bridging vehicle with 6,5 tonnes cross country payload

Dimensions

Length, with ribbon bridge	10.27 m
without ribbon bridge	8.75 m
Width, with bridge	3.45 m
Height, with bridge	4.00 m
Wheelbase	5.35 m
Track - front	2.05 m
Track - rear	2.10 m
Overhang front	1.50 m
Overhang rear without bridge	1.90 m

Weights

Kerb weight:	13.700 kg
Payload	6.500 kg
Front axle, permissible	6.150 kg
Rear axle, permissible	14.000 kg
GVW permissible	20.150 kg

Performance

Angle of approach, laden	30°
Angle of departure, laden	20°
Belly clearance	0.45 m
Ground clearance	0.32 m
Fording depth, unprepared:	
front	max. 0.75 m
rear	max. 1.20 m
Gradient, laden without trailer	max. 50%
Side angle	max. 30%
Speed continuous, approx.	88 km/h
Turning circle	22 m
Range (fuel tank 300 ltr.)	min. 600 km

Drive line

Engine

Make	DAF
Type	DHS 825, diesel, 4-stroke 6-in-line, direct injection, turbocharged, liquid cooled (charge cooling)
Bore and stroke	118 x 126 mm
Displacement	8.25 litres
Compression ratio	15:1
Output	184 kW (250 hp)/2400 rpm According to DIN 70020 (EC 72/306)
Torque	915 Nm (93.3 kgfm)/1500 rpm
Fuel pump governor	All-speed
Torque converter:	
Make	ZF
Type	WSK 400/25
Ratio	max. 2.3

Gearbox

Make	ZF
Type	5 S-111 GPA, 8 speed forward and 1 speed reverse
Ratio 1st gear	8.66:1
2nd gear	6.18:1
3rd gear	4.48:1
4th gear	3.51:1
5th gear	2.53:1
6th gear	1.80:1
7th gear	1.31:1
8th gear	1.02:1
Reverse	12.03:1

Dropbox

Make	ZF
Type	A 600/3D, incl. lockable diff. in permanent front wheel drive. Dropbox is an integral part of the gearbox. The gearbox ratios shown include the dropbox ratio (1.02:1).

Front axle

Make	Kirkstall
Type	DS 65
Ratio, final incl. hubreductions	5.48:1
Brake area p/wheel	1290 sq. cm.

Rear bogie

Make	DAF
Type	2699 T, with lock. diff.
Ratio, final incl. hubreduction	5.48:1
Brake area p/wheel	1680 sq. cm.
Bogie is provided with a lockable interaxle differential.	

Wheels and tyres

Wheels	10.00 x 20 tubeless
Tyres	14.75/80R20 Michelin XL; single mounting

Frame

Designed as a common ladder type platform (partly bolted and partly riveted), comprising of two U-type longitudinal members and U-type and Omega-type crossmembers; the longitudinal members are reinforced over the full length.

Suspension

Front suspension	
Make	DAF
Type	Semi-elliptic
Specific deflection	3.13 mm/kN
Shock absorber front	Koni type 90 telescopic double acting, adjustable

Rear suspension

Make	DAF
Type	Semi-elliptic
Specific deflection	0.46 mm/kN

Steering

Make	ZF
Type	8046 hydraulic, power assisted

Brake system

Type	Air mechanical, 2 line, dual circuit in acc. to EC regulations
Operating pressure	600-800 kPa (6-8 bar)
System guard	Bendix air-dryer
Parking brake	Spring brake cylinders on front axle and second rear axle
Retarder	Exhaust brake
Trailer brake connection	not applicable
Trailer brake	not applicable
Brake force adjustment	not applicable

Electrical equipment

System	Splashproof/radio suppressed
Voltage	24V
Alternator	28V/55A
Battery	2 x 125 Ah
Starter motor	6.6 hp/5 kW
Connector	Slave connector, trouble light connector at rear and front
Lighting	Standard commercial vehicle lighting and black-out lighting according to NATO requirements
Controls	Instrument panel is provided with a revolution counter, a speedometer, a combined unit comprising, a temperature gauge, a pressure gauge, a fuel gauge, and warning lights for main/dipped beam, direction indicators, air inlet vacuum sensor, parking brake, oil temperature torque convertor, PTO, lock-up of differentials.

Towing facilities At front a NATO push-pull pin. The front bumper is provided with 2 towing and 2 lifting eyes.

Cab Tilt cab is derived from the commercial F 218 cab. Three seats available.

Production meets the NATO Quality Control System Requirements for Industry AQAP 1 (Stanag 4108).